

BOSS
MOUNTAIN-BIKE SUSPENSION

IDYLLLE

Model year 2014

USER MANUAL

WARRANTY



Terms and conditions

BOS MTB offers warranty on its products on the following terms : BOS MTB guarantees the original purchaser that the BOS product for which they received this warranty is free from defects in material and workmanship for one year from the date of original retail purchase. A proof of purchase will be asked for any warranty claim. This warranty is not transferable to a subsequent purchaser. Wear and tear parts such as dust seals, Oring, bushings, rear shock mounting hardwares, stanchions, threaded parts and bolts are not covered under this warranty.

Terms

This warranty is subject to legal jurisdictional or warranty rights of the country where it has been originally purchased, which will prevail if different from the terms herein listed.

Limits

BOS MTB cannot be liable for any loss, inconvenience damages, whether direct, incidental, consequential, resulting from the use of its products, local legislation prevailing.

Warranty exclusions

This warranty does not cover the following cases:

- Damage to products resulting from improper assembly other than listed below
- Products that have been modified by the owner or a third party
- Improper use
- Damages resulting from an accident, crash under any circumstances
- Invalid servicing procedures and servicing time frame not respected
- Replacement of the original parts by parts from others manufacturers
- Products whose serial numbers has been altered, defaced or removed.

Warranty procedure

The owner should always refer to an approved BOS center for any warranty claim. A proof a purchase is compulsory for any warranty claim. Otherwise the warranty claim will not be considered. Always contact BOS MTB warranty department before returning any products that may fall under this warranty. If “the faulty parts” do not fall under warranty, the customer will be charged for any costs in respect with warranty such as transport and package back and forth.

SETTINGS & MAINTENANCE



1. ASSEMBLY

Fitting your Idylle onto your bike demands care and attention.
For your safety, please do respect the following instructions.

1.1 The steerer tube

Before cutting the steerer tube, first you have to take some measurements :
Height of the headset, length of the headtube of the frame, height of the stem and then add 5 to 10mm.

With a standard stem clamped on the steerer tube :

Add the length of the headtube of the frame to the height of the headset and to height of the headset plus 5 to 10mm.

With a stem bolted onto the upper crown :

Add the length of the headtube of the frame to the height of the headset plus 5 to 10mm.

CAUTION

Never attempt to remove or replace the steerer or upper tubes independently from the crown. Modifying the integrated crown, steerer, or upper tubes can cause an assembly failure, resulting in a loss of control of the bicycle and serious injury.

1.2 Stanchions and crowns

Depending on the bike, the position of the stanchions in the crowns may slightly differ. Nevertheless, it is actually very important to follow all the measurement advices listed below, to ensure a perfect function, and a total security.

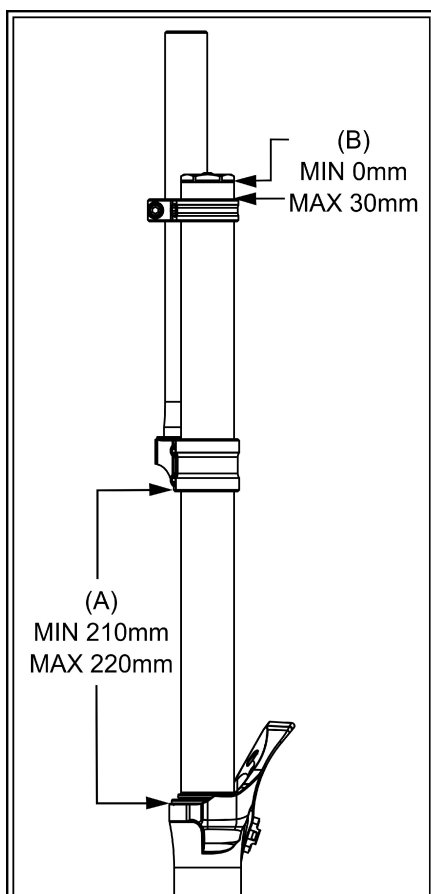

When installing the wheel with a properly inflated tyre, make sure that the forks achieve minimum tyre clearance. Simply measure the distance from the top of the leg (lower part of the seal) to the outer of the lower crown, it has to be between 210mm to 220mm (A).

IMPORTANT

This distance is for tyres of a maximum diameter of 705mm.

The distance between the top of the upper tubes and the top of the upper crown must be included between 0mm and 30mm.

Once the forks assembled to the measurements listed above you can then tighten but always refer to the recommended tightening torque.

Tightening torque for all bolts of the upper and lower crown : 4 to 5 N.m.

1.3. Installing the front wheel

To assemble the front wheel, check the following procedure :

1. Loosen the four axle pinch bolts on the lower leg with a 5 mm hex key wrench.
2. Using a 6 mm hex key wrench, turn the axle counter-clockwise to loosen and remove.
3. Install the front wheel into the dropouts and install the axle into the lower leg.
4. Put a small amount of grease on the thread of the axle and, using a 6 mm hex key wrench, turn clockwise and lightly tighten the axle to the lower leg.
5. Tighten the two left side (caliper side) dropout pinch-bolts to 3N.m torque
6. Compress the fork on the bike a couple of times to let the right side of the dropout float and settle to its low-friction point. Tighten the two right side dropout pinch-bolts 3N.m torque.

1.4. Disc brake installation

The Idylle disc bolt pattern uses caliper mount for post mount 160 (PM160).

To assemble the disc brakes, check the following procedure:

1. Install the DH disc brake system, according to disc brake manufacturer's specifications.
2. Be sure to torque all fasteners and bolts to manufacturer's recommendations. Consult the instructions that came with your disc brakes for proper installation procedures. It is recommended to install a NEW disc brake pads, to ensure proper alignment and to minimize drag.
3. Route the disc brake hose (for hydraulic disc brakes) or brake cable housing (for mechanical disc brakes) from the caliper to the inside of the lower leg and through the supplied disc brake hose guide.
4. Tighten the disc brake hose guide screw (M3 x 12) with a 2.5 mm-hex key wrench, and torque it to 1N.m.
5. Test the brakes for proper operation on level ground before hitting the trails.

The disc brake caliper mounting bolts must have 10 mm of thread engagement with the fork.

In any case, the disc brake caliper mounting bolt tightening torque level must never exceed 10N.m.

2. SETTINGS

2.1. Air pressure (IDYLLE Rare and IDYLLE Air)

The sag measurement is the amount that your fork, rear shock, or both will compress when you are positioned for riding on your bike, with all your riding apparel and gear. Adjusting air pressure until you achieve your target sag will help you to determine the appropriate amount of air pressure for your fork or shock, or both.

To achieve the best performance from your BOS suspension product, the proper measuring and setting of sag is vitally important. As a starting point, set sag for your fork or rear shock according to the following instructions:

Recreational use

weight(kg/lbs)	55/120	60/132	65/143	70/154	75/165	80/176	85/187	95/210	105/231	110/242
pressure (psi)	155	160	165	170	175	180	185	190	195	205

Racing use

weight(kg/lbs)	55/120	60/132	65/143	70/154	75/165	80/176	85/187	95/210	105/231	110/242
pression (psi)	160	165	170	175	185	190	195	200	210	215

Minimum air pressure: 155 psi

Maximum air pressure: 215 psi

The Idylle have an o-ring on the fork upper tube in order to measure the SAG position. You can experiment and vary your sag percentage to better suit your riding style and overall feel.

2.2. Coil spring (IDYLLE)

To get the best performance from your Idylle fork, it is necessary to set and occasionally preload the spring rate. By default, your forks come with the orange spring within. Two extra springs (green and grey) come in the box in order to adjust to most of the riders.

See the Idylle coil spring setting table below for reference. You may need to install a coil spring having a different spring rate.

weight (kg/lbs)	< 60 kg < 132 lbs	de 60 à 80 kg from 132 to 176 lbs	de 80 à 105 kg from 176 to 231 lbs	> 105 kg > 131 lbs
spring	green	orange	grey	purple
availability	extra	origin	extra	option

Spring Preload

Generally, sag should be set to 15 – 25% of total fork travel (30 to 50mm)

1. The Idylle have an o-ring on the fork upper tube in order to measure the SAG position. Slide the o-ring down against the scraper lip of the fork dust seal.
2. Dressed to ride, position your bike in dynamic situations (going down the hill for instance). Without bouncing, mount your bicycle. Assume a normal riding position for at least 30 seconds, allowing the suspension to fully settle.
3. Dismount your bike without bouncing downward, without further moving the o-ring. Measure the distance between the seal and the o-ring. This measurement is your sag value.
4. Compare your sag measurement value to the sag recommendations: 30 to 50mm

If your sag measurement value is less than the sag recommendations, turn the preload knob counter-clockwise with a 14mm wrench. Measure sag again and repeat adjustment if necessary.

If your sag measurement value is greater than the sag recommendations, turn the preload knob clockwise with a 14mm wrench. Measure sag again and repeat adjustment if necessary.

If the preload adjustment is greater than 20 clics, you need to install a coil spring with a stronger rate.

Changing the coil spring

1. With a 32 mm 6-point socket wrench, loosen and remove the preload top cap (top of left leg) (pictures 1 & 2)
2. Remove the black spring guide. (picture 3)
3. Compress the fork slightly and remove the coil spring. (picture 4)
4. Wipe the spring dry with a rag and check the color code.
5. Install the new spring by dropping it into the upper tube.
6. Install the black spring guide, then torque the top cap to 24 N.m.
7. Measure and set sag. Adjust the preload topcap adjustment, if necessary.

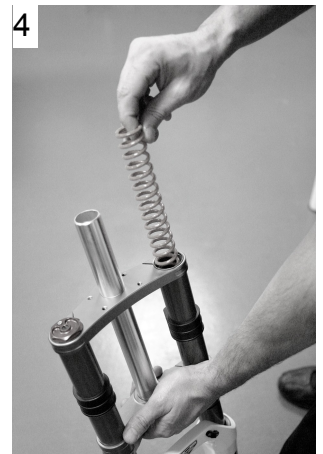

2.3. HYDRAULIC ADJUSTMENTS

IDYLLE Rare

IDYLLE Rare comes with 3 hydraulics adjustments: low speed compression, high speed compression, and rebound

The **low speed compression** adjustment seats at the bottom of the right hand leg using a flat head screwdriver(1-A).

The **high speed compression** adjustment seats at the bottom of the right hand leg using a 14mm 6 points socket wrench (1-B).

The rebound adjustment is on the top of the right hand tube using a flat screwdriver(2).

Always start from fully tighten position, then tighten down counting the clicks to adjust your settings.

Tighten (anticlockwise) = close / harden
Undo (clockwise) = open / soften

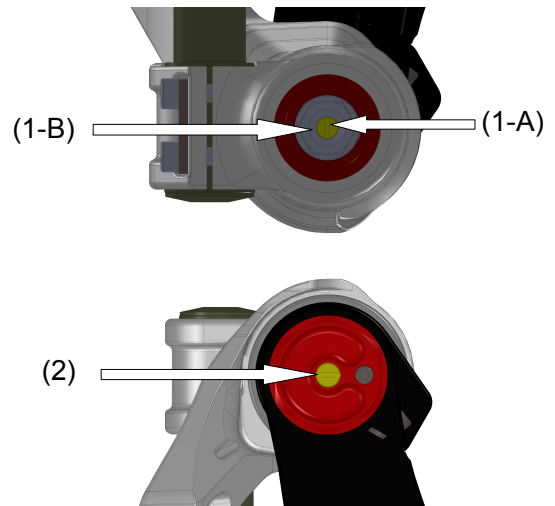

Tuning tips :

When it comes down to hydraulic setting there is no such thing as a magical formula, many factors have to be taken into account (bike balance, spring rate, geometry of the bike...).Having said that you can draw conclusions from what follows :

- Excessive diving of the bike upon braking : harden the LS compression.
- Often bottom out: harden the HS compression.
- Feeling harsh on roots or square edges : soften HS compression
- Uncomfortable, arms pain : soften rebound.
- The forks don't spring back and stay low after succession of bumps : soften rebound.
- Front too high (in dynamic situation) : harden the rebound.

Whenever you are far from the standard settings (factory settings) It's always better to consider what influences the performance of the forks. Proceed step by step, one setting at a time by hardening or softening few click each time. If you ever get lost while you are setting up the forks, always go back to its original settings.

Starting point adjustments - IDYLLE Rare

Recreational use

Low speed compression : 15 clicks from the fully tighten position.
High speed compression: 18 clicks from the fully tighten position.
Rebound : 18 clicks from the fully tighten position.

Racing use

Low speed compression : 10 clicks from the fully tighten position.
High speed compression: 20 clicks from the fully tighten position.
Rebound : 16 clicks from the fully tighten position.

IDYLLE Air & IDYLLE

IDYLLE Air and IDYLLE comes with 2 hydraulics adjustments: compression and rebound

The compression adjustment seats at the bottom of the right hand leg (flat head screw) (1)

The rebound adjustment is on the top of the right hand stanchion (the non-disc side) (2)

Always start from fully tighten position, then tighten down counting the clicks to adjust your settings.

Tighten (anticlockwise) = close / harden

Undo (clockwise) = open / soften

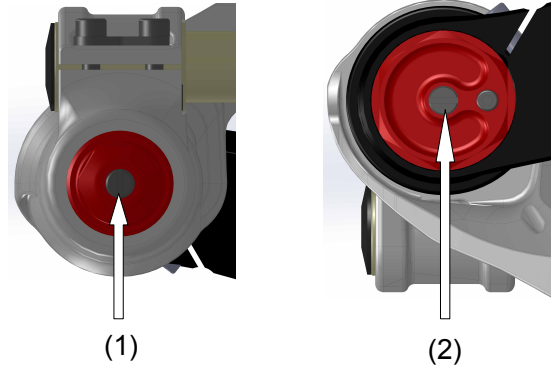

Tuning tips :

When it comes down to hydraulic setting there is no such thing as a magical formula, many factors have to be taken into account (bike balance, spring rate, geometry of the bike...). Having said, that you can draw conclusions from what follows :

- Excessive diving of the bike upon braking : harden the compression.
- Often bottom out: harden the compression.
- Feeling harsh on roots or square edges : soften the compression
- Uncomfortable, arms pain : soften the rebound.
- The forks don't spring back and stay low after succession of bumps : soften the rebound.
- Front too high (in dynamic situation) : harden the rebound.

Whenever you are far from the standard settings (factory settings) It's always better to consider what influences the performance of the forks. Proceed step by step, one setting at a time by hardening or softening few click each time. If you ever get lost while you are setting up the forks, always go back to its original settings.

Starting point adjustments – IDYLLE Air

Recreational use

Compression : 15 clicks from the fully tighten position.
Rebound : 18 clicks from the fully tighten position.

Racing use

Compression : 8 clicks from the fully tighten position.
Rebound : 16 clicks from the fully tighten position.

Starting point adjustments – IDYLLE

Compression : 15 clicks from the fully tighten position.
Rebound : 18 clicks from the fully tighten position.

3. MAINTENANCE

3.1 Air bleeding

Idylle is fitted with a bleeding screw on the top of the right stanchion.

Bleeding your forks on regular basis will reduce the pressurising effect that always happens with those forks.

We recommend to bleed your fork every 5 rides in racing use or every 10 rides in recreational use.

All you have to do is to undo the bleeding screw and put them back on, no need to compress the forks.

3.2. Cleaning your fork

It is compulsory to clean your fork every time you use it, without waiting !

Nothing's worse for your fork's seals than dry mud.

It is very simple to clean your fork : wipe off the stanchion with a clean rag and then slightly lube the stanchion (with silicon based product). Using of degreaser is totally forbidden.

On the same note, do not power wash the fork! It will only push the mud inside the fork and get it stuck between the stanchion and the seals.

	Cleaning	Air bleeding	Oil service	full service
Recreational use	After each ride	Every 10 rides	once a year	Every 2 years
Racing use	After each ride	Every 5 rides	twice a year	once a year

IMPORTANT

The oil service and full service must be performed by a BOS approved center. The BOS approved centers are the only able to identify and appraise a damaged or worn parts, especially in case of shock or wear on structural elements such as the legs, the stanchions and the crowns.

3.3. Changing oil

An oil change with the Idylle fork consists in changing the oil bath in each leg. Keep highly attention about the correct oil level, in both leg (cartridge and spring), follow the datas mentioned below in the table.

CAUTION

To get the correct oil level in the cartridge side, you must bleed the air while you are pouring the oil. Once there is no air remaining in the cartridge you can adjust the level, referring to the table below.

IMPORTANT

This is strongly recommended to use BOS Bi'oil oil, otherwise it could significantly alter the behaviour of the fork and reduce the life of the wear parts.

How to measure the oil level, in the cartridge side :

- Push down the stanchion
- Pull out the rebound rod
- Measure the distance between the top of the stanchion and the oil

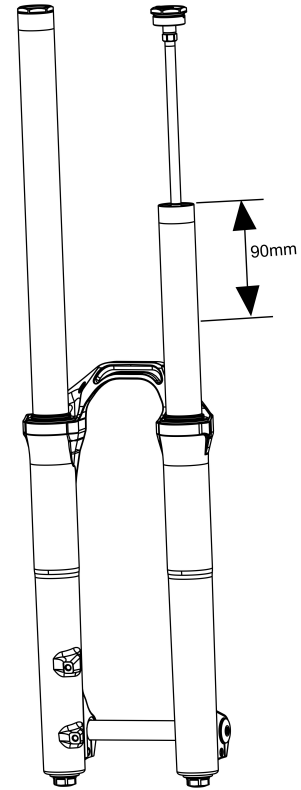

Oil level

	IDYLLE Rare	IDYLLE Air	IDYLLE
Damping side (right)	110mm	185mm	190mm
Spring side (left)	10ml	10ml	140ml

4. FAQ

What initial settings for the fork?

The "Idylle Chart list" is available on the download section of the bosmtb.com website. The « Idylle Chart list » summarizes the recommended settings (clicks and air pressure) depending on the body weight. Refer also to chapter 2 of this manual for details.

There is an air leaking when I connect the high pressure pump, what can I do?

Check with a Schrader valve tool if it is screwed correctly or check your pump.

At rest position, the fork travel is slightly engaged (small SAG), is this normal?

The BOS air spring system is designed to offer the lowest threshold of release. Some forks may come with a slightly negative travel.

Where can I get the original stickers or valve cap?

Those items are available on the online store on bosmtb.com. Or contact our sales department for informations commercial@bosmtb.com.

The fork comes with a slightly play on stanchions area, what can I do?

The unique alignment of the bushings of the BOS forks creates an induced slight frontal play. If the play is abnormally high, please contact BOS approved center for expertise.

The fork retracts when I deflate the air chamber, what's happening?

Deflating the fork means removing the air from the positive chamber only. The remaining air on the negative air chamber creates an opposite force to the main spring and retracts the fork. To avoid this, deflate step by step (30/40 psi) and alternate with very slow oscillations (5 or 6) on the first 15 mm of travel to recover the full travel.